



HiScroll 46, scroll pump, three-phase motor without GB, including ATEX



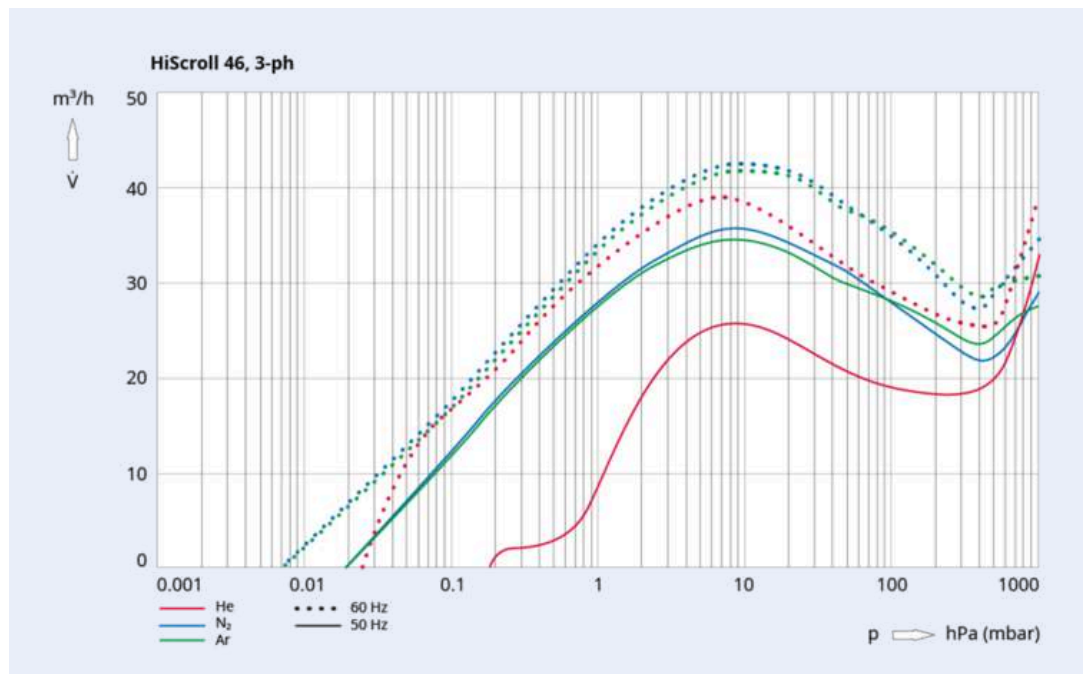

Illustration only

HiScroll 46, scroll pump, three-phase motor without GB, including ATEX

- No hydrocarbons: Completely dry & oil-free Scroll vacuum pump
- Ultra-quiet and low-vibration - perfect for laboratories and quiet working environments
- Safe operation thanks to standard built-in non-return valve, hermetically sealed pump system and IP44 protection for industrial environments
- Seamless integration - Compact design, easy to implement and flexible thanks to Harting connector power supply
- Maximum efficiency and performance - shortest pump-down time with lowest energy consumption
- Sustainable: Lowest power consumption at final pressure, lower heat generation and lower cooling requirements
- ATEX conformity: Ex II 3 (internal)/- (external) G Ex h IIC T4 Gc X +5 °C ≤ Ta ≤ +40 °C
- Simple logistics: Our HiScroll pumps are suitable for all voltages worldwide
- Low operating costs thanks to the highest quality, short maintenance times and long maintenance intervals

Characteristics



Dimensions

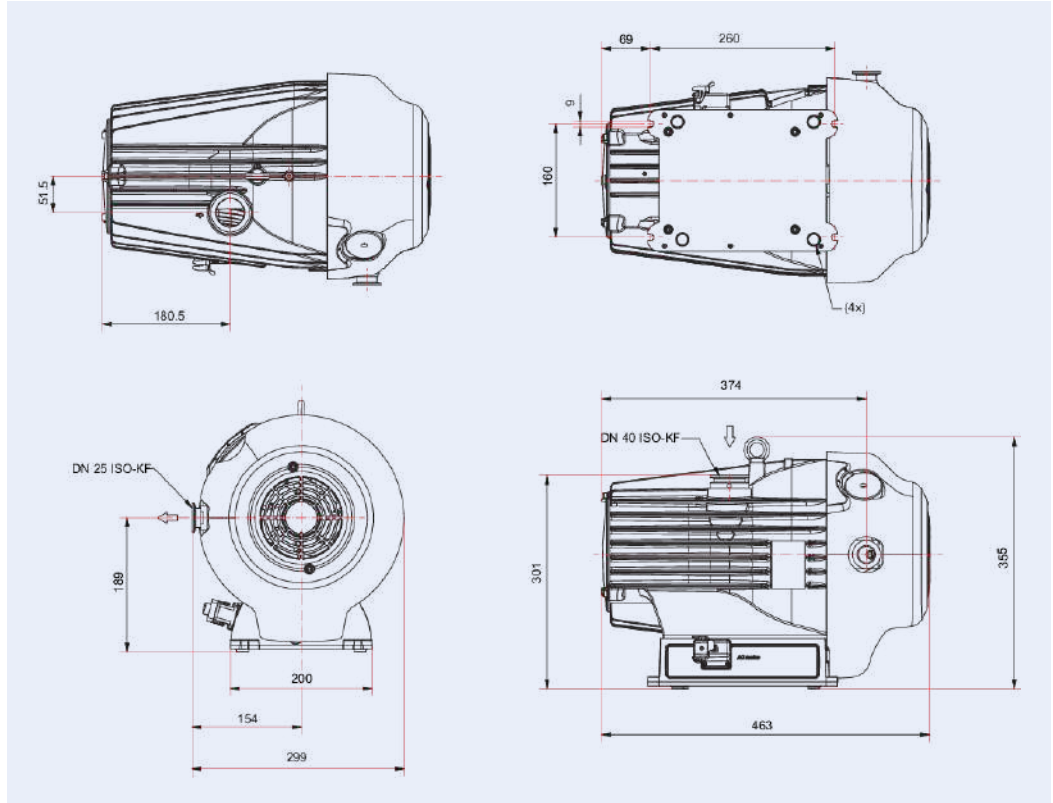

Technical Data	HiScroll 46, scroll pump, three-phase motor without GB, including ATEX
Gas ballast	No
Cooling method	Air (Forced convection)
Ambient temperature	5 – 40 °C
Certification	cTUVus certified according to UL / CSA 61010-1
ATEX-certification	Ex II 3/-G Ex h IIC T4 Gc X +5 °C ≤ T _a ≤ +40 °C
Pumping speed at 50 Hz	35 m ³ /h 20.601 cfm 583.345 l/min
Pumping speed at 60 Hz	43 m ³ /h 25.31 cfm 716.68 l/min
Input voltage(s)	190 – 220 / 380 – 415 V AC, 50 Hz 200 – 240 / 380 – 480 V AC (±5 %), 60 Hz
Emission sound pressure level (EN ISO 2151)	≤55 dB(A)
Ultimate pressure	7 · 10 ⁻³ hPa 5.25 · 10 ⁻³ Torr 7 · 10 ⁻³ mbar
Ultimate pressure for gas ballast stage 1	3 · 10 ⁻² hPa 2.25 · 10 ⁻² Torr 3 · 10 ⁻² mbar
Ultimate pressure for gas ballast stage 2	2 · 10 ⁻¹ hPa 1.5 · 10 ⁻¹ Torr 2 · 10 ⁻¹ mbar
Ultimate pressure at 50 Hz	0.02 hPa 0.015 Torr 0.02 mbar
Ultimate pressure at 60 Hz	0.007 hPa 0.005 Torr 0.007 mbar
Tested base pressure	7 · 10 ⁻³ hPa 5.25 · 10 ⁻³ Torr 7 · 10 ⁻³ mbar
Exhaust pressure, max.	1,200 hPa 900 Torr 1,200 mbar
Rotation speed at 50 Hz	1,460 rpm 1,460 min ⁻¹
Rotation speed at 60 Hz	1,760 rpm 1,760 min ⁻¹
Operating altitude, max.	3,000 m
Intake pressure max.	1,100 hPa 825 Torr 1,100 mbar
Mains cable	No
Dimensions (L x W x H)	463 x 299 x 334 mm
Connection flange (in)	DN 40 ISO-KF
Connection flange (out)	DN 25 ISO-KF

Order number	HiScroll 46, scroll pump, three-phase motor without GB, including ATEX
HiScroll 46, scroll pump, three-phase motor without GB, including ATEX	PD S40 201

Accessories	HiScroll 46, scroll pump, three-phase motor without GB, including ATEX
TipSeal maintenance kit for HiScroll 46	PD E40 000 -T
Valve set for HiScroll 46	PD E43 000 -T



伯东企业（上海）有限公司
HAKUTO ENTERPRISES (SHANGHAI) LTD.
TEL: (86) 21-5046 3511

上海伯东 -- 您理想的真空合作伙伴！

伯东公司成立于 1953 年，外企上市企业，全球范围内有一千七百名员工，集团年营业额约为 100亿人民币。

伯东公司在国内主要城市：上海，北京，苏州，广州，深圳，成都及厦门设有营业据点。

上海伯东真空产品事业部已累计为超过 10,000 家企业提供真空服务

我们致力于追求高品质的服务，为您提供一流的服务及一流产品：

品质保障：国际知名品牌指定授权代理商，所有产品及部件保证 100% 原厂原装进口

现货交期快：部分产品有现货，下单立即发货（现货数量有限，实际情况请联系销售工程师）

卓越维修能力：伯东工程师拥有10年以上维修经验，且受国外专业培训，拥有完全的拆解，维修，校正能力。

完美服务质量：原装进口检测设备全方位寻找问题症结及全方面的性能测试，确保完美的服务质量



伯东企业（上海）有限公司 销售及售后服务中心

上海浦东新区新金桥路1888号36号楼7楼702室

电话：+86-21-5046-3511 / 139-1883-7267

传真：+86-21-5046-1490

官网：<http://www.hakuto-vacuum.cn>

